

Notes

1. All below ground drainage in UPVC & MUPVC to BS 45214 & 5225, all tested and installed in accordance with BS 8301
2. All above ground drainage Cast Iron to BS 460 and installed and tested to BS 5572
3. All soil and waste pipes below 76mm in copper to BS 2871 Table X and swept sanitary fittings to BS 864 Part 2 1983.
4. All below ground drainage falls at a minimum of 1:40.
5. For Manhole Schedule see drawing No B052/MIRD.

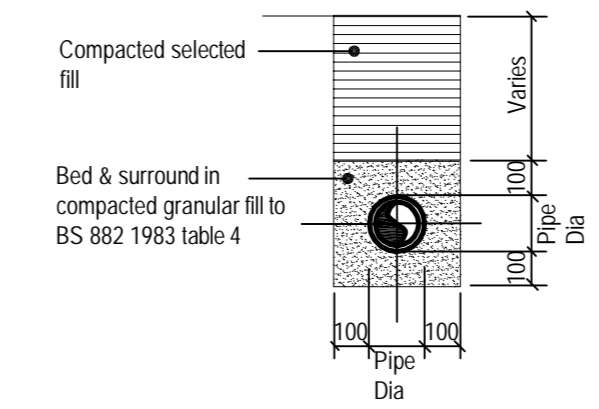

TYPICAL PIPE TRENCH FOR FOUL & SURFACE WATER DRAINS

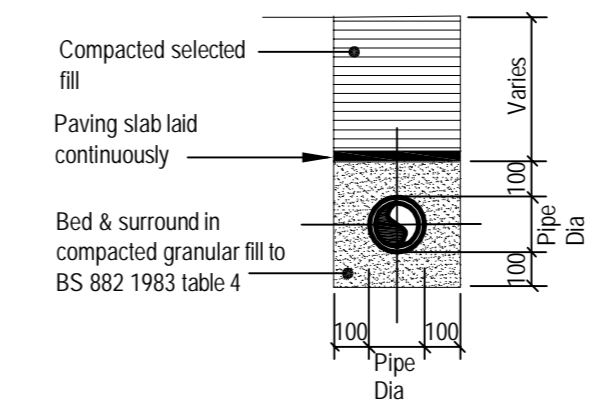

TYPICAL PIPE TRENCH FOR FOUL & SURFACE WATER DRAINS WHEN LAID WITH LESS THAN 600mm COVER

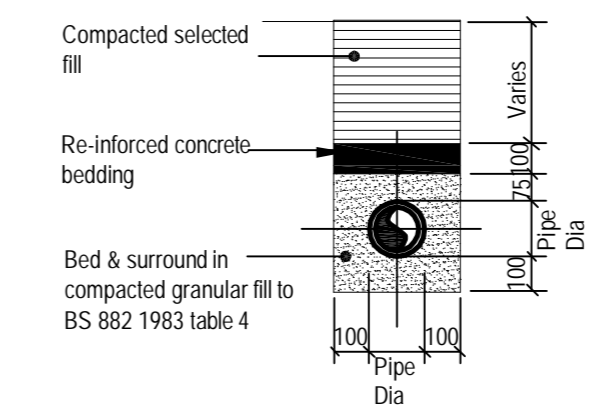

TYPICAL PIPE TRENCH FOR FOUL & SURFACE WATER DRAINS WHEN LAID UNDER ROADS WITH LESS THAN 900mm COVER

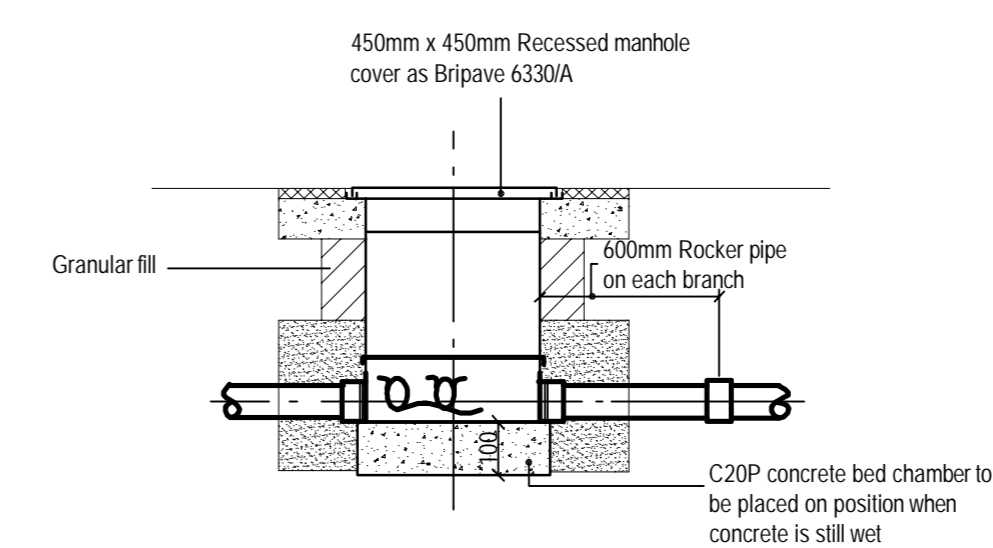

SECTION DETAIL OF MANHOLE

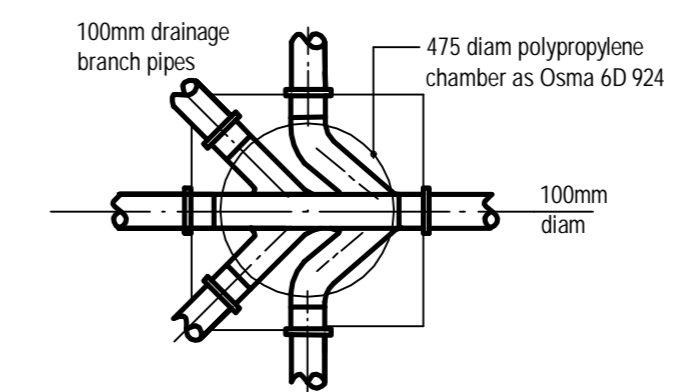

PLAN DETAIL OF MANHOLE

